

Model GT54

User's Manual



I have this manual



Please read this manual carefully before using the scooter

Trademarks or registered trademarks of affiliated enterprises. The names of other companies, products, or services mentioned may be trademarks or registered trademarks of their respective owners.

Riding times Robot (Shenzhen) Technology Co., Ltd. All rights reserved.

Welcome

Join the Riding'times community of riders wherever you are!
This is just the beginning of your adventure with us! We look forward to hearing
about your experience and seeing you on our social media platforms
Mark us! ! @Ridingtimes #Ridingtimes



Install your electric scooter:

YouTube account name: Riding'times Global

Link: [Youtube.com/@ridingtimesamazon6449/playlists](https://www.youtube.com/@ridingtimesamazon6449/playlists)

Customer Service

EN:Our product technology is already very mature, with 20 years of trade, we have distributors all over the world who can provide you with the most localized and professional technical support within 24 hours.

DE:Unsere Produkttechnologie ist sehr ausgereift, mit 20 Jahren Handel haben wir weltweit Vertreter, die Ihnen innerhalb von 24 Stunden die bestmögliche lokalisierte und professionelle technische Unterstützung bieten.

FR:Notre technologie de produit est déjà très mature, avec 20 ans de commerce, nous avons des distributeurs partout dans le monde qui peuvent vous fournir le soutien technique le plus localisé et professionnel dans les 24 heures.

IT: La tecnologia dei nostri prodotti è già molto matura, con 20 anni di commercio, abbiamo distributori in tutto il mondo che possono fornirvi il supporto tecnico più localizzato e professionale entro 24 ore.

ES Nuestra tecnología de producto ya es muy madura, con 20 años de comercio, contamos con distribuidores en todo el mundo que pueden brindarle soporte técnico altamente localizado y profesional en un plazo de 24h

NL:Onze producttechnologie is al zeer volwassen, met 20 jaar handel hebben we distributeurs over de hele wereld die u binnen 24 uur de meest lokale en professionele technische ondersteuning kunnen bieden.

▶ If you need to return a product, please contact your dealer first and return it in the original packaging.

Certifications

Federal Communications Commission (FCC) Compliance Statement for USA

FC This device complies with part 15 of the FCC rules. Operation is subject to the following two conditions: (1) This device may not cause harmful interference, and (2) this device must accept any interference received, including interference that may cause undesired operation .

Note: This equipment has been tested and found to comply with the limits for a Class B digital device, pursuant to part 15 of the FCC Rules. These limits are designed to provide reasonable protection against harmful interference in a residential installation. This equipment generates, uses and can radiate radio frequency energy and, if not installed and used in accordance with the instructions, may cause harmful interference to radio communications. However, there is no guarantee that interference will not occur in a particular installation. If this equipment does cause harmful interference to radio or television reception, which can be determined by turning the equipment off and on, the user is encouraged to try to correct the interference by one or more of the following measures:

-Reorient or relocate the receiving antenna.

-Increase the separation between the equipment and receiver.

-Connect the equipment into an outlet on a circuit different from that to which the receiver is connected.

Consult the dealer or an experienced radio/TV technician for help.

This equipment complies with FCC radiation exposure limits set forth for an uncontrolled environment.

European Union Compliance Statement Battery recycling information for the European Union

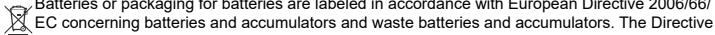

Batteries or packaging for batteries are labeled in accordance with European Directive 2006/66/EC concerning batteries and accumulators and waste batteries and accumulators. The Directive determines the framework for their return and recycling of used batteries and accumulators as applicable throughout the European Union. This label is applied to various batteries to indicate that the battery is not to be thrown away, but rather reclaimed upon end of life per this Directive. In accordance with the European Directive 2006/66/EC, batteries and accumulators are labeled to indicate that they are to be collected separately and recycled at end of life. The label on the battery may also include a chemical symbol for the metal concerned in the battery (Pb for lead, Hg for mercury, and Cd for cadmium). Users of batteries and accumulators must not dispose of batteries and accumulators as unsorted municipal waste, but use the collection framework available to customers for the return, recycling, and treatment of batteries and accumulators. Customer participation is important to minimize any potential effects of batteries and accumulators on the environment and human health due to the potential presence of hazardous substances.

Restriction of Hazardous Substances Directive (RoHS)

RoHS Our products sold in the European Union, on or after 3 January 2006 meet the requirements of Directive 2011/5 EU on the restriction of the use of certain hazardous Substances and electrical and electronic equipment ("RoHS recast" or "ROHS 2*").

Europe-European Union Notice

CE This products with the CE alert marking comply with the rules issued by the Commission of the European.

IMPORTANT SAFETY INSTRUCTIONS

Even if you are an experienced bike rider, all riders should read and understand this manual before using an electric bike. For your safety and to avoid serious injury or death, please closely review the following safety tips for safe operation of your Electric Bike.

IMPORTANT SAFETY INSTRUCTIONS

WARNING - When using this product, basic precautions should always be followed, including the following:

- a) Read all the instructions before using the product.
- b) To reduce the risk of injury, close supervision is necessary when the product is used near children.
- c) Do not put fingers or hands into the product.
- d) Do not use this product if the flexible power cord or output cables frayed, has broken insulation, or any other signs of damage.
- e) For all equipment, the instructions shall indicate "This equipment is not intended to be used at ambient temperatures less than 0° or above ambient temperatures of 40°C. The blanks are to be filled in with the manufacturer's specified ambient temperature ratings.
- f) For all equipment, the instructions shall indicate "The battery is intended to be charged when the ambient temperature is between 0° and 40°. Never charge the battery when ambient temperatures are outside this range." The blanks are to be filled in with the manufacturer's specified ambient temperature range for charging.

SAVE THESE INSTRUCTIONS

INSTRUCTIONS IMPORTANTES CONCERNANT LA

Avertissement - lors de l'utilisation de ce produit, les précautions de base doivent toujours être suivies, y compris les suivantes:

- A) lisez toutes les instructions avant d'utiliser le produit.
- B) pour réduire le risque de blessure, une surveillance étroite est nécessaire lorsque le produit est utilisé près des enfants.
- C) ne mettez pas les doigts ou les mains dans le produit.

D) n'employez pas ce produit si le cordon d'alimentation flexible ou les câbles de sortie s'effilochent, a l'isolation cassée, ou tout autre signe de dommages.

E) pour tous les appareils, les instructions doivent indiquer: «cet appareil n'est pas destiné à être utilisé à des températures ambiantes inférieures à 0° ou supérieures à des températures ambiantes de 45°C. Les ébauches doivent être remplies avec les valeurs de température respectives spécifiées par le fabricant. SÉCURITÉ CONSERVER CES INSTRUCTIONS

F) pour tous les appareils, les instructions doivent indiquer: «cet appareil n'est pas destiné à être utilisé à des températures ambiantes inférieures à 0° ou supérieures à des températures ambiantes de 45°C. Les ébauches doivent être remplies avec les valeurs de température respectives spécifiées par le fabricant. SÉCURITÉ CONSERVER CES INSTRUCTIONS

IMPORTANT SAFETY INSTRUCTIONS“ and ”SAVE THESE INSTRUCTIONS

WARNING (AVERTISSEMENT)

-This E bike is a leisure device. But once they're in a public area, they'll be seen as vehicles, subjecting to any risks faced by vehicles. For your safety, please follow instructions in the manual and traffic laws and regulations set forth by government and regulatory agencies. For example, setting the max. Please note that We are not responsible for any financial loss, physical injuries, accidents, legal disputes, or other conflicts of interest resulting from actions that violate user instructions and local regulations.

-Always wear an approved helmet whenever riding this product.

- Inspect the bike before each use, making sure the correct setup and tightening is done on your bike before using it for the first time. Check the brake function, handlebar grips, tightening and lubricating components regularly.

- Check the operation of the brake motor cutoff before each ride. The brake system, when properly functioning cuts off power to the motor whenever the brakes are squeezed.

-Always use the lowest pedal assist level, or lightest throttle, until you are comfortable with the bike and feel confident with the equipment.

- Users must travel at speeds appropriate for the usage area, riding conditions, and experience level.

-Because electric bikes are significantly heavier than regular bikes, they are not intended for large jumps or stunts of any kind. Bike frames and parts have limitations, and extreme riding should not be performed.

-We do not assume any responsibility for any accidents, injuries, or property damage caused by the rider's use or misuse, including any damage caused by off-road use of this product.

- In the event of a collision or presumed damage, you must consider your bike unsafe to ride until a comprehensive inspection of all components, functions, and operations of the bike can be made by a certified, reputable bike mechanic.

- Do not operate the bike without the battery installed.

DANGER

- Proper installation, compatibility, operation, and maintenance must be performed on all components. Failure to comply could result in serious injury or death. When installing the battery, any water or ice on the battery connector can cause the battery to burn out. The key is used to remove the battery, inserting the key into the charging port can also cause the battery to burn out. Avoid touching the two metal contacts of the battery box at the same time, as it may generate a large short-circuit current and lead to an accident. Any aftermarket changes or modifications to your bike could void the warranty and create an unsafe riding experience.
- Ride at night only if necessary. Wear reflective clothing; if possible, only bike down roads with ample street lighting. Ensure you have reflectors and lights as required by your regional vehicle laws.
- Take extra precaution when riding in wet conditions. Decrease speeds and prepare for increased braking distance. Pedals and grips will be slippery in wet conditions.
- NEVER operate your bicycle when you are under the influence of alcohol or drugs, including prescribed or over the counter medications.
- Failure to properly charge, store, or use your battery will void the warranty and may cause a hazardous situation.
- Failure to perform and confirm proper installation, compatibility, proper operation, or maintenance of any component or accessory can result in serious injury or death.
- If you have an impairment or disability such as visual impairment, hearing impairment, physical impairment, cognitive/language impairment, and/or a seizure disorder, consult your physician before riding our bikes.
- Be careful to keep your body parts and other objects away from the sharp teeth of chain rings, moving chain, turning pedals and crank, and the spinning wheels of your bicycle.
- The bike is not designed for wading. If water level reaches the wheel hub of the rear motor, it may cause a short circuit and damage the electrical system.
- Do not lend the electric bike to someone who cannot operate it safely to avoid unnecessary damage and accidents.
- Obey traffic regulations and do not carry passengers on the bike.
- At the same time, you should understand that risks cannot be entirely avoided as others may violate traffic regulations and drive incautiously, and you're exposed to road accidents just as when you're walking or biking. The faster the bike is, the longer it takes to stop. On a smooth surface, the bike may slip, lose balance, and even result in a fall. Thus it is crucial that you use caution, keep proper speed and distance, especially so when you're unfamiliar with the place.
- Storage instructions: Wipe the body, wheels, and handles with a damp cloth to remove dust, dirt, and stains.

WARNING (AVERTISSEMENT) -Do not use water guns or other methods to wash the vehicle to avoid short circuits caused by water ingress into the electronic control system

-Abandoned instructions: Please do not dispose of this product at will. It should be disposed of in accordance with local recycling regulations

INSTRUCTIONS PERTAINING TO A RISK OF FIRE OR ELECTRIC SHOCK IMPORTANT SAFETY INSTRUCTIONS

- Battery failure: Batteries are the main hazard of electric bicycle fires. Overcharging, use of non original chargers, battery aging or damage (such as collision, internal short circuit after compression) can all cause the battery to heat up, bulge, and even ignite or explode.
- Line problem: After long-term use, the wiring inside the car may age, be damaged, or be overloaded due to unauthorized modifications (such as adding high-power equipment), causing short circuits and fires.
- Storage environment: Storing in high temperature environments (such as cars exposed to sunlight in summer, enclosed corridors) or in close contact with flammable materials (cardboard boxes, fabrics, etc.) can increase the risk of fire.
- Line damage: The insulation layer of the wires inside the vehicle is worn or broken, especially in humid environments, which may cause electric shock to the human body after contact.
- Charging equipment issues: Damaged charger, loose interface, or use of unqualified charging equipment may cause electrical leakage, posing a risk of electric shock when plugging in and out the plug.
- Improper maintenance: Non professionals may accidentally connect wires or fail to properly insulate them during maintenance, which may also cause electric shock.

SAVE THESE INSTRUCTIONS

MOVING AND STORAGE INSTRUCTIONS Instructions de déplacement et de stockage

- Before riding, check the brakes, battery level, tire pressure, and handlebar flexibility to ensure that all components are functioning properly.
- Choose a dry, ventilated place that is protected from direct sunlight and rain and snow (such as indoor garages, storage rooms), and avoid long-term exposure to high temperatures (over 40 °C) or low temperatures (below -10 °C) to prevent battery and vehicle components from aging.

CONTENTS

1.COMPONETS DIAGRAM -----	9
2.INSTALLATION INSTRUCTIONS-----	10
3.PARAMETER TABLE-----	13
4.BATTERY-----	14
5.OPERATING INSTRUCTIONS-----	15
6.CHARGER-----	18
7.USER MAINTENANCE INSTRUCTIONS-----	18
8.OIL BRAKE MAINTENANCE-----	19
9.TROUBLESHOOTING INSTRUCTIONS-----	23
10.DEFECTS LIABILITY PERIOD-----	23

COMPONENTS DIAGRAM

1. Sticker Area

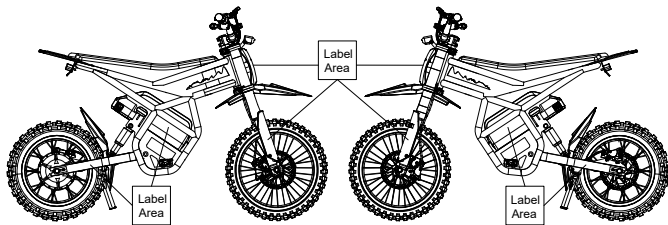

2. Components Diagram

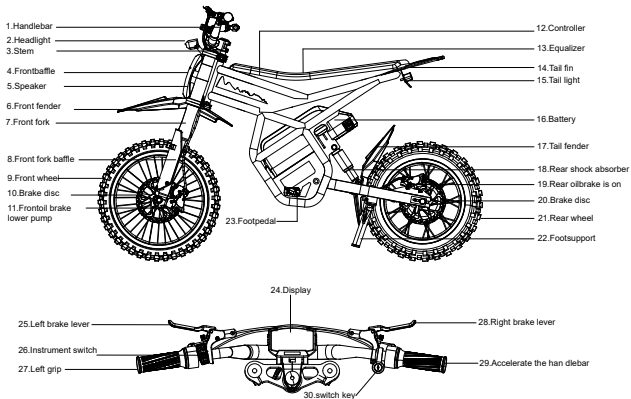

INSTALLATION INSTRUCTIONS (INSTRUCTIONS D'INSTALLATION)

-Take out of the electric bike from the box



-Assemble the handlebar: Put the handlebar into the center of the vertical bar , fasten the screws by using NO.4 Allen Wrench

WARNING- Failure to properly tighten handlebar components may result in loss of control, serious injury or death. Always check the handlebar cannot move and is secured to the frame before riding the bicycle.

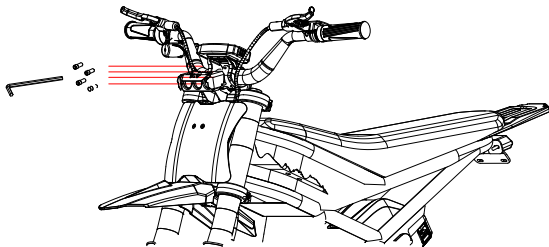

-Install the front fender and fix the screws with a No. 5 Allen wrench.

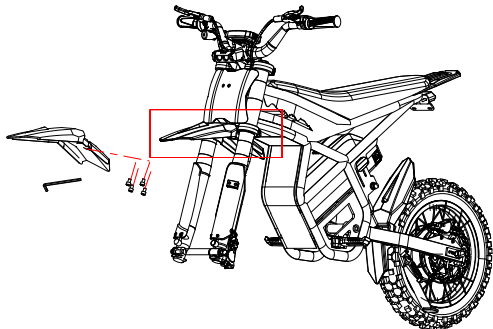

- Install the front wheel (First align the front wheel with the front fork hole, install the thru-axle, use a No. 22 Allen key to tighten the screws slightly)

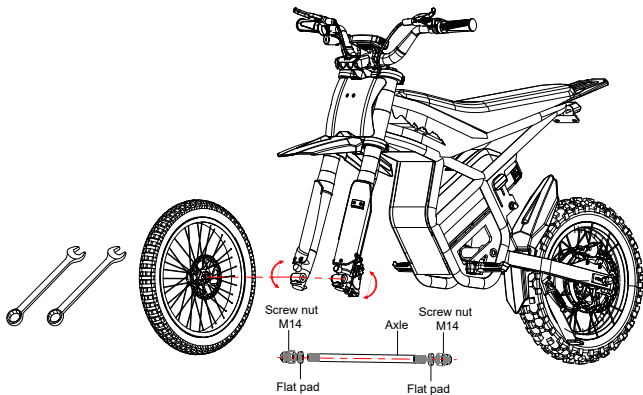

-Manage the cable harness: Take out of the winding tube from the accessory box, tie the left and right wire harnesses together.

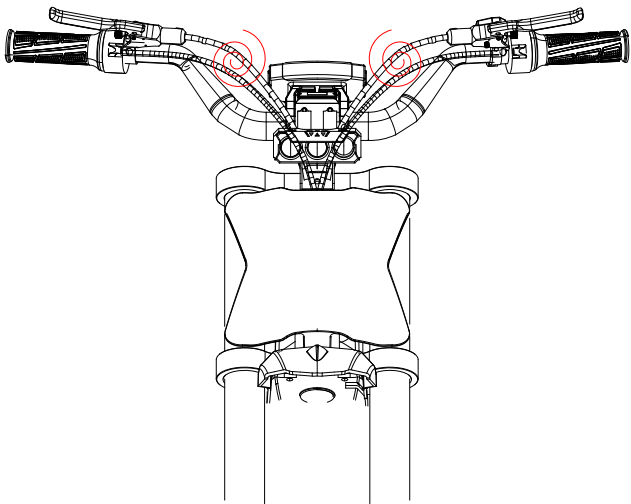

PARAMETER TABLE

Model	GT54
Product name	Electric dirt bike
Battery model	48V/ 27Ah
Battery weight	About 6.8KG
Charger	54.6V/3A
Charging time	8.5-9H
Motor name	E35 Bicycle Motor
Display	Digital display instrument LED
Brake	Front and rear oil brakes + electronic brakes
Special function	Quick release battery pack
Damping	Front hydraulic double wishbone shock absorber/rear shock absorber
Tire specifications	Front wheel: 60/100-14 Rear wheel: 60/100-12
Weight	About 48.3KG
Gross weight	About 58.3 KG
Expand Size	1518*670*1010MM (length*width*height)
Package Size	1420*28*800MM(length*width*height)
Maximum load capacity	220lbs
Design minimum load capacity	88lbs
Minimum age of use	16 years old
Gradeability	15<
Top speed	15mph
Note	There are certain errors in the manual measurement of the above data. The data may not be updated in time. Please understand!

BATTERY

Manufacturer	Guangdong Liwang New Energy Co., Ltd.		
Model No	GT54		
Capacity	48V 27Ah		
Maximum Charging Current	5A		
Maximum Discharge Current	45A		
Charging Temperature Range	0~40℃		
Discharging Temperature Range	-20~45℃		
Storage temperature	0℃~60℃	≤1month	charged to about 40% to 60% of capacity
	0℃~45℃	≤3 month	
	0℃~25℃	≤1 year	

OPERATING INSTRUCTIONS (INSTRUCTIONS D'UTILISATION)

-Overview of Instrument/Button Functions and Distribution of Functional Areas

- Front headlights ● Push mode ● Sport mode ● Normal mode ● Energy saving mode
- Maximum speed ● Battery display ● Single mileage display ● Speed display ● Total mileage
- upshift button ● function button ● downshift button ● power on/off button ● electric door lock
- headlight button ● Left turn button ● Right turn button ● Horn button

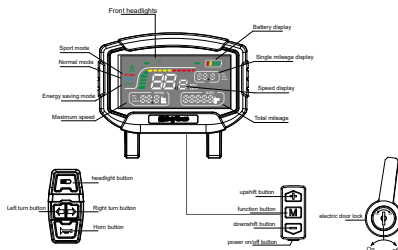

-Instrument operation instructions

-Power on/off

Power on and power-off steps Firstly, ensure that the battery is locked and the red switch on the battery is turned on (set to -). Open the power lock and turn on the power. Press and "⏻" hold the button for 2 seconds to turn on the device and enter P mode (Figure 1-1). Pinch the brake to enter normal mode (Figure 1-2). If there is no operation within 30 seconds

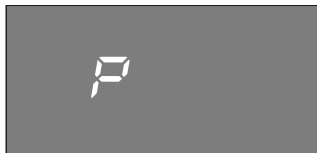

1-1



1-2

-Mode switch:

Press the power button "3" times to switch to the power-assist mode and the throttle will be disabled. Press the power button "3" times again to switch the coexistence of throttle and power-assist.

-Gear switching:

Press the "S" key to switch the ECO/STD/TURBO gear (Figure 1-3), and long press the "M" key to enter the boost mode

The boost mode allows access to the low-level settings interface. (at this time the pedestrian icon on the display lights up, Pinch the brake and exit) (Figure 1-4).



1-3



1-4

-Set mode:

-Enter/exit the setting interface: long press the "S" key and (Figure 1-5) "S" at the same "⏏" time



1-5

-Function menu switching: In the setting interface state, Press "⏏" to increase the menu options upward; Press "⏏" to decrease the menu options downward;

- Function menu parameter switching: In the function menu interface state, Press the "S" key to increase the parameters upward; Press the "M" key to decrease the parameters downward;

- Function menu options:

P01: Kilometer unit. 0: KM; 1: MPH; default 1 (Figure 1-6)



1-6

P02: Restore factory settings: long press the "S" key, Restore factory settings when 0 becomes 1 (Figure 1-7)



1-7

P03: Brightness adjustment. 1. Darkest; 2 is normal; 3 brightest; Default 3 (Figure 1-8)

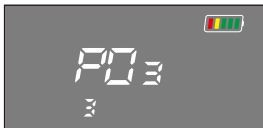

1-8

P04: Sleep time setting: 1-60 minutes; default 10 minutes (Figure 1-9)

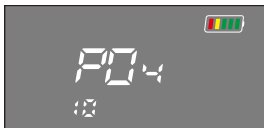

1-9

P05: Clear total mileage: Long press the "S" key, Clear the total mileage when 0 becomes 1 (Figure 1-10)

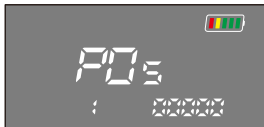

1-10

CHARGER

WARNING- Use only charger model JY-546300 Input: 100-240V~, 50/60Hz, 2.5A; Output: 54.6Vdc, 3.0A (E480338-20240116) (Guangzhou JiYin Power Electronics Co Ltd)

AVERTISSEMENT- Utilisez seulement le modèle de chargeur JY-546300 Entrée: 100-240V ~, 50/60Hz, 2.5A; Sortie: 54.6Vdc, 3.0A (E480338-20240116) (puissance de Guangzhou JiYin) Electronics Co Ltd

USER MAINTENANCE INSTRUCTIONS INSTRUCTIONS D'INTERTEINANCE DE L'UTILISATEUR

- If your bicycle is very dirty, please clean it with water or a mild detergent and non abrasive sponge while driving.
- Do not use high-pressure cleaning for bicycles.
- Do not directly clean the bearing points or electronic components of electric bicycles.
- Do not use irritating chemicals or alcohol wipes to clean bicycles.
- Please use lubricating oil to wipe the metal parts of the bicycle body for maintenance.
- It is strictly prohibited to lubricate the brake and wheel hub.

Lubrication section	lubrication interval	Recommended lubricating oil
Front fork component	a year	Butter (lithium grease)
Front and rear axles	a year	Butter (lithium grease)
Centre shaft	a year	Butter (lithium grease)
Pedal shaft	a year	Butter (lithium grease)
Chain wheel teeth	a year	lubricant
Chain	a year	lubricant
Inside the wheels	January	lubricant
Brake handle	January	lubricant

OIL BRAKE MAINTENANCE

-Please read the manual before maintenance and do not leave it to inexperienced personnel.

12.2 The upper and lower pumps of this product produce braking function by extrusion through the oil pipe output. The internal oil should be maintained after 10 months under normal use (except for other improper use) to avoid air generated inside the brake pump causing braking. If the effect is not good

or fails, please go to a professional repair shop or professional repairman for maintenance.

12.3 Operation steps (scan the second microcode on the homepage and there is a video explanation)

- Adjust the screw to the middle position
- Remove the brake, remove another piece, and insert the gear plug
- Remove the brake oil seal screw

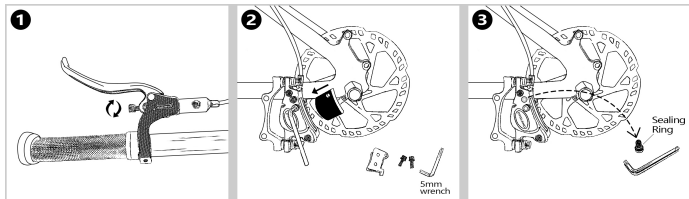

d. Insert the long hose into the oil injection barrel, connect the hose and the oil hole with the oil injection nozzle, and tighten the screws manually

e. Slightly loosen the handbrake lever lock cover screw, adjust the handbrake lever to be flush with the handle, and then tighten the screw

f. Open the oil seal screw of the handbrake lever (note that there is a sealing ring on the oil seal screw)

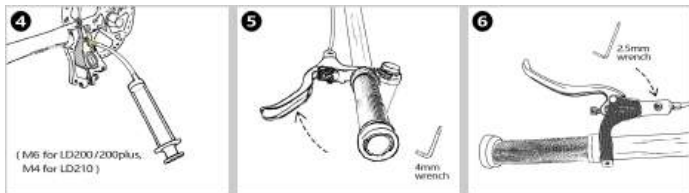

- g. Insert the short hose into the oil filling barrel, connect the hose and the oil cylinder with the M4 oil filling nozzle connector, and then tighten the screws by hand.
- h. Use another oil filling cylinder to extract 20ml of new engine oil
- i. Inject engine oil into the oil filling cylinder



- j. The oil filling barrel should be kept vertical. The oil injected into the barrel will gradually decrease. Make sure there is oil in the barrel throughout the process, otherwise air will be sucked in.
- k. Push out the air and squeeze the oil filling cylinder. The oil priming cartridge is then extracted, which draws air from the oil. Apply extraction several times until bubbles are no longer visible in the oil filler barrel, or only a small amount of bubbles are visible in the extraction extraction

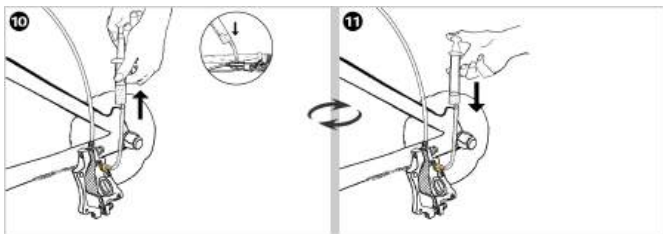

- l. During the last pump, a little oil is left in the oil filling barrel.
- m. Replace the oil filling cylinder with the exhaust gas cylinder. When pulling out the oil filling barrel, wrap it with a cloth to prevent oil from overflowing.
- n. Apply as much pressure as possible on the brake side.

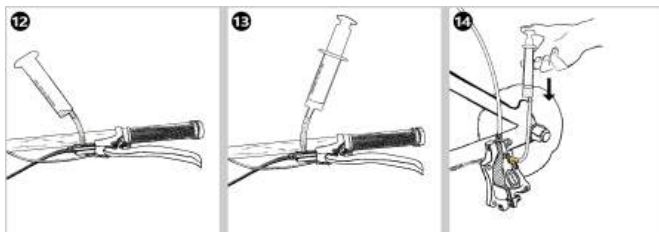

- o. Then loosen the grease nipple and tighten the sealing screw again
- p. Use paper towels to wipe off the remaining oil on the upper surface of the brakes
- q. Remove the gear plug, install the brake pads, and reinstall the brakes to the vehicle.

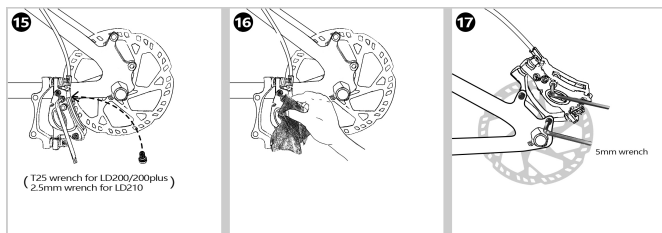

- r. Bleed the air from this end of the handbrake lever and extract the air from the tube
- s. Repeat extraction several times until no bubbles or very few bubbles are visible in the tube.
- t. After the last injection, loosen the interface and tighten the oil seal screw.

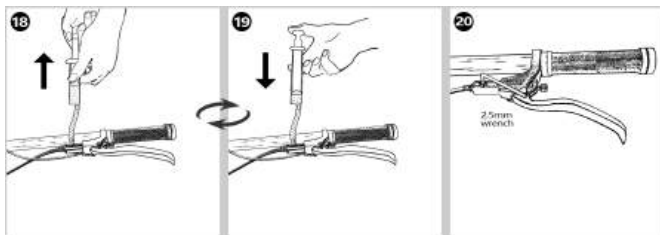

- u. Use a paper towel to wipe off the remaining oil on the surface of the handbrake.
- v. Slightly loosen the handbrake lever lock cover screw, adjust it to the appropriate angle and retighten the screw.
- w. Adjust the elastic screw on the handbrake lever to achieve a satisfactory feel.

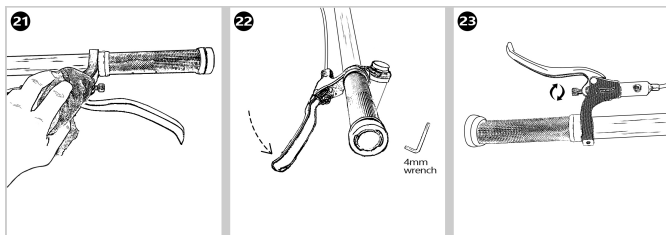

TROUBLESHOOTING INSTRUCTIONS

Instrument error code

Fault code	Fault name	Fault code	Fault name
E02	Brake failure	E08	Motor phase line short circuit/MOS tube failure
E06	Arrears protection	E09	Controller failure
E07	Electric Hall failure	E10	Controller/instrument communication failure
E011	Handle failure	HOT	Temperature protection

DEFECTS LIABILITY PERIOD

-Warranty information and contact information

Company:Shenzhen Riding Robot Tech Co., Ltd

Address:5A-504, Building 2, No. 309 Ping'an Avenue, Liang'antian Community, Pinghu Sub-district, Longgang District, Shenzhen

Email: Support@riding-times.com

Phone: 86-0755-29483035

-Non warranty coverage

- All man-made damages, such as water immersion, improper use of power supply, improper use of accessories, etc.
- Damage and unreasonable maintenance due to failure to use reference product specifications.
- The damage caused by the unreasonable dismantling by Party A is not covered by the warranty commitment.
- The closure is opened; The connector is damaged.
- The outer shell and display screen of the electric vehicle were scratched or damaged after delivery.
- Malfunctions or damages caused by force majeure events such as fires, earthquakes, etc. Or natural disasters (such as lightning strikes, etc.).
- The warranty period has expired